

CORRUGATED BUCK ANCHOR

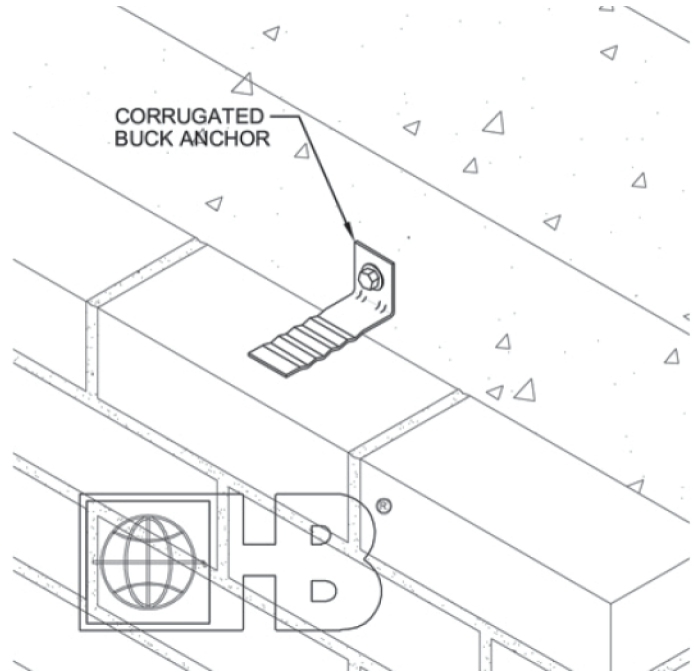
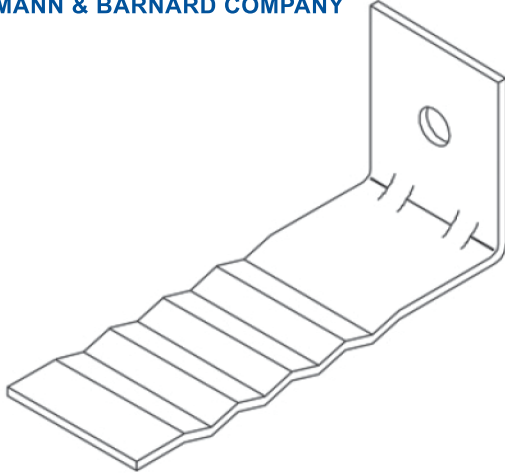

DRAWINGS FOR ILLUSTRATIVE PURPOSES ONLY

QUANTITY:

MATERIAL CONFORMANCE:

Sheet Metal

Carbon Steel

ASTM A1008/A1008M

Zinc coating:

Mill Galvanized

ASTM A653/A653M (0.6 oz/ft²)

Hot-Dip Galvanized

ASTM A153/A153M-B2 Class B

ASTM A123/A123M

Stainless Steel

Type 304: **ASTM A276/A276M, ASTM A582/A582M**

Type 316: **ASTM A240/A240M, ASTM A582/A582M**

Corrugated Buck Anchor Finish:

Mill Galvanized

Hot-Dip Galvanized

Type 304 Stainless Steel

Type 316 Stainless Steel

Note: H&B recommends Stainless Steel for maximum protection against corrosion.

Note: Bend is 1 1/2" long.

Thickness:

16 gauge

14 gauge

12 gauge

Width:

1 1/4"

2"

Other _____

Length:

3 1/2"

5 1/2"

Other _____

Standard hole is 5/16"Ø. Other sizes available on request below.

Custom hole size _____

PROJECT NAME:

LOCATION:

NOTES:

CONTACT INFO

Name :

Company:

Phone:

FAX:

Email:

The appropriate selection and use of any product contained herein must be determined by competent architects, engineers and other professionals who are familiar with the specific requirements of the project.